

Gillison's Variety Fabrication, Inc.

Manufacturers of quality farm equipment since 1977.



ROUGH TERRAIN FORKLIFTS

GVF Rough Terrain Forklifts are fast, powerful machines that operate smoothly. Available in four different models. These lifts get the job done quickly and comfortably.

• Models:

- GVF 5000, 6000 & 8000, available in 2WD and 4WD.
- GVF 4000, 4WD - NEW Compact design to navigate narrow rows and tight spaces. * See separate literature.
- Tier III Turbo JCB engine
- See through mast
- 48" carriage with 6 rollers
- 8" side shift in carriage
- 4 flood lights - 2 front, 2 rear
- LED direction indicator lights
- LED warning flasher lights
- Backup alarm
- Horn
- SMV emblem
- Tilt and telescoping steering column
- Suspension seat
- Engine pre cleaner
- Down or vertical exhaust
- Rear view mirror
- 4 section hydraulic valve
- 150 cu. in. tool box
- Painted with high quality urethane paint
- Options:
 - 2 or 4 wheel drive
 - Grid heater for cold start
 - Warning beacon
 - Bin clamp
 - Bin dumper
 - Rear fender
 - Front fender extensions
 - Transmission brake
 - Load backrest



New ESO-MS Mast offers better visibility.



GVF 5000 Tier III Turbo



GVF 5000 shown with GVF Bin Dumper



GVF 4000

GVF 5000

On the left is the GVF 4000 - Compact design to navigate narrow rows and tight spaces.

* See separate literature.

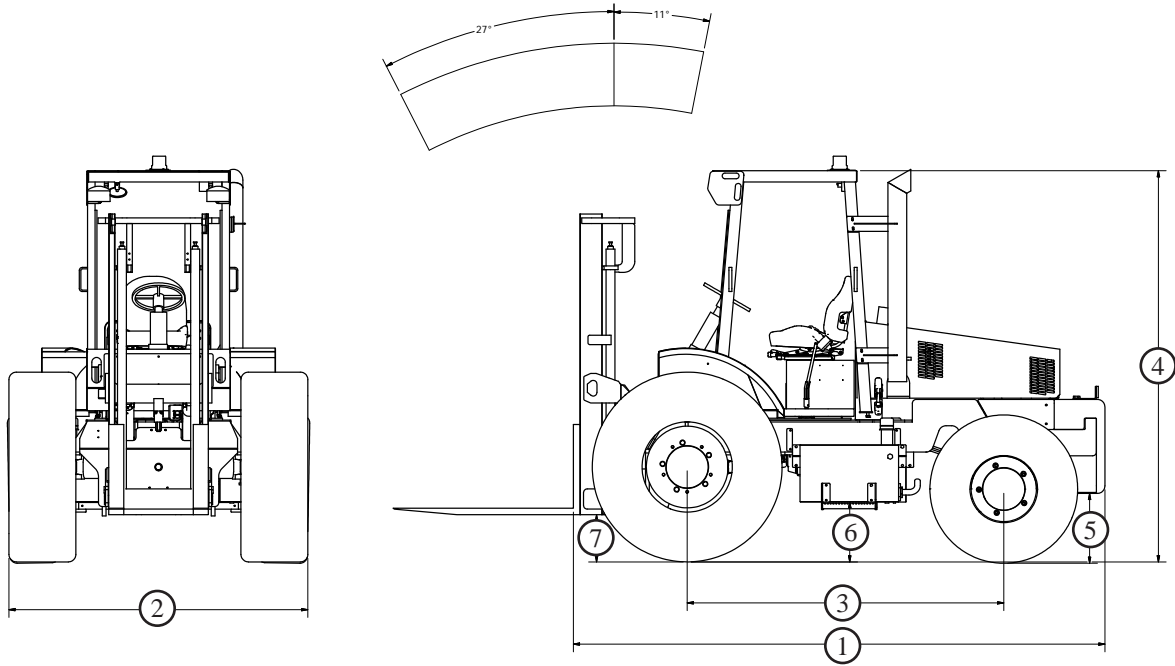

| SPECIFICATIONS | Drawing Reference Number | GVF 5000 | GVF 6000 | GVF 8000 |
|---------------------------------|--|--|-------------|-------------|
| Overall length (without forks) | 1 | 139.5" | 139.5" | 158" |
| Overall width | 2 | 80" | 80" | 87" |
| Wheel base | 3 | 84" | | |
| Height to top overhead guard | 4 | 102" | | |
| Clearance under counterweight | 5 | 18.5" | | |
| Transmission clearance | 6 | 18.5" | | |
| Clearance under mast | 7 | 13" | | |
| Weight | | 12,000 lbs. | 13,000 lbs. | 16,190 lbs. |
| Lift capacity @ 24" load center | | 5,000 lbs. | 6,000 lbs. | 8,000 lbs. |
| Mast tilt forward | | 30° | 30° | 25° |
| Mast tilt rearward | | 11° | 11° | 12° |
| Mast side shift | | 8" | | |
| Outside turning radius | | 12' | | |
| Standard lift height | | 12' | | |
| Travel speed | | 18.5 MPH | | |
| Tire Size | GVF 5000 & 6000: Drive: 16.9-24, 10 ply, R4 Steer: 12.5-80R-18, 10 ply, R4 | GVF 8000: Drive: 19.5L-24, 10 ply, R4 Steer: 12.5-80R-18, 10 ply, R4 | | |
| Steering | Load sense power steering, 2.5 turns lock to lock | | | |

| | |
|-----------------------------|--|
| Engine Manufacturer & Model | JCB 444 Tier III Mechanical Diesel |
| Cylinders | 4 |
| Fuel system | Rotary mechanical |
| Engine gross HP | 84.5 @ 2200 RPMs |
| Peak torque | 236 lb/ft @ 1200 RPMs |
| Start aid cold weather | Grid heater |
| Transmission | 4-speed synchro-shuttle |
| Fuel tank capacity | 25 gallons |
| Parking brake | External disc |
| Front axle | Self locking torque proportioning differential internal wet disc brake |
| Rear axle | 4 wd self locking torque proportioning differential 20° oscillation |
| Hydraulic pump | 24 gpm @ 2200 RPMs |
| Control valve | 4 section, 1 aux |
| System pressure | 2500 psi |
| Electrical | |
| Voltage | 12 volt |
| Alternator | 95 amp |
| Battery rating | 950 cca |

2 or 4 wheel drive models available.